

Section C-C
A8

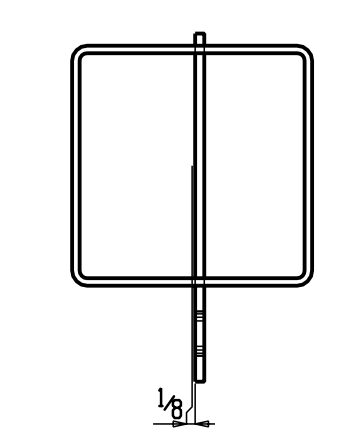

Section B-B
A8

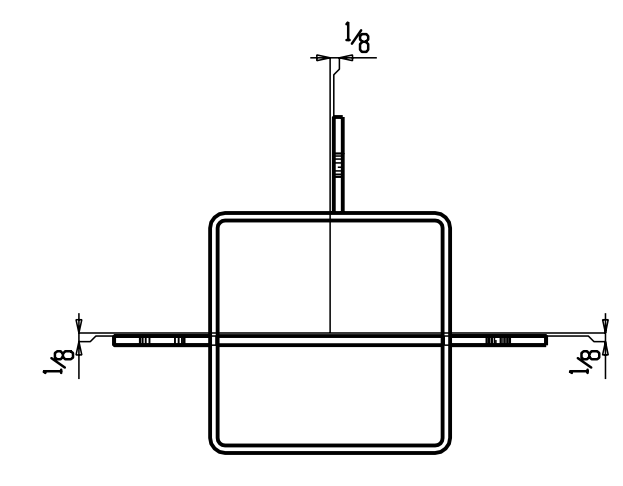

Section A-A
A8

BILL OF MATERIAL

Mark	Quantity	Description	Length	Steel	Remarks	Sequence
A8	ONE	COLUMN				1
cb4	1	TS10x10x5/8	31	A500B	SCE	
p39	1	PL 3/8x18	1	A36		
p36	1	PL 3/8x12	1	A36		
p37	1	PL 3/8x12	1	A36		
fb7	1	FL 3/8x4	1	A36		
fb22	1	FL 3/8x4	0	A36		
cp2	1	PL 1/4x10	0	A36		

MATERIAL ASTM A36 U.O.N.
 WELDING ELECTRODE: E70XX
 SURFACE PREP SSPEC-SP2
 SHOP FINISH 3 COAT SHOP PRIMER 2 MILS DFT MIN. U.N.O.

HOLES
 U.O.N. 13/16" Ø

SUBJECT COLUMNS
 PROJECT
 LOCATION PLATTE CITY, MD
 CUSTOMER

DESIGNED BY
 DESIGN/ERECTION DWG REF S2.1-S2.2, S4.1-S4.2/E1-E4

DRAWN BY	DATE	CHECKED BY	DATE
TRJ	12-5-04	JFS	4-1-04

Sheet No. 8 Sale No. 0363

DATE	REV	DESCRIPTION