

BILL OF MATERIAL

Piece Mark	Quantity	Description	Length	Steel Grade	Remarks	Sequence Numbers	Quantity
A32	ONE	COLUMN				1	1
uu174	1	W12x106	44	A992	SEC		
pp4	1	PL 1/2x21 1/2	2	A36			
pp9	1	PL 3/4x18 1/2	1	A36			
pp10	4	PL 3/8x5 3/4	0	101 3/16	A36		
pp46	1	PL 1/2x12 1/4	1	0 7/8	A36		
pp14	8	PL 1/2x5 3/4	0	101 3/16	A36		
pp60	2	PL 3/8x5 3/4	0	101 3/16	A36		

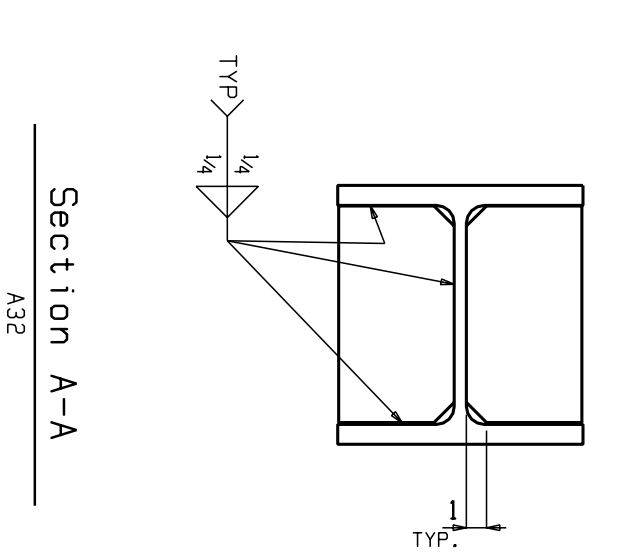
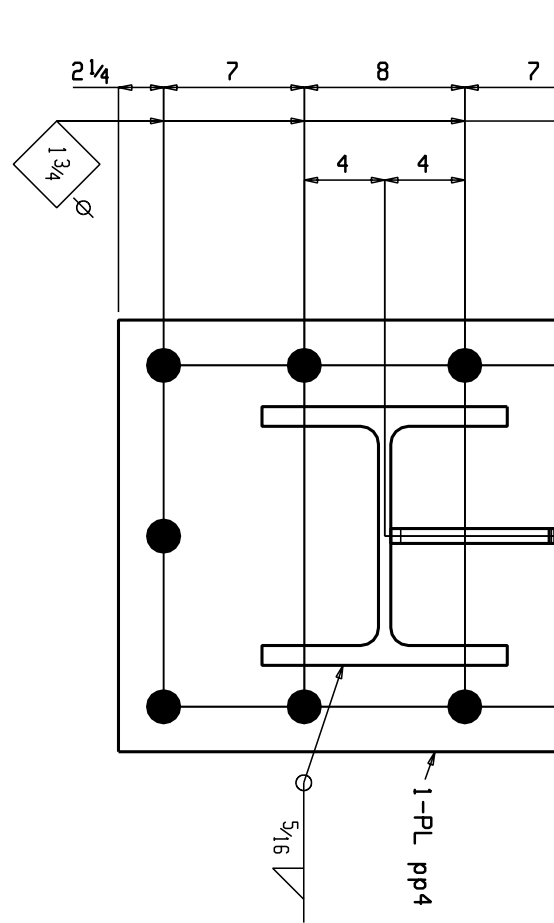
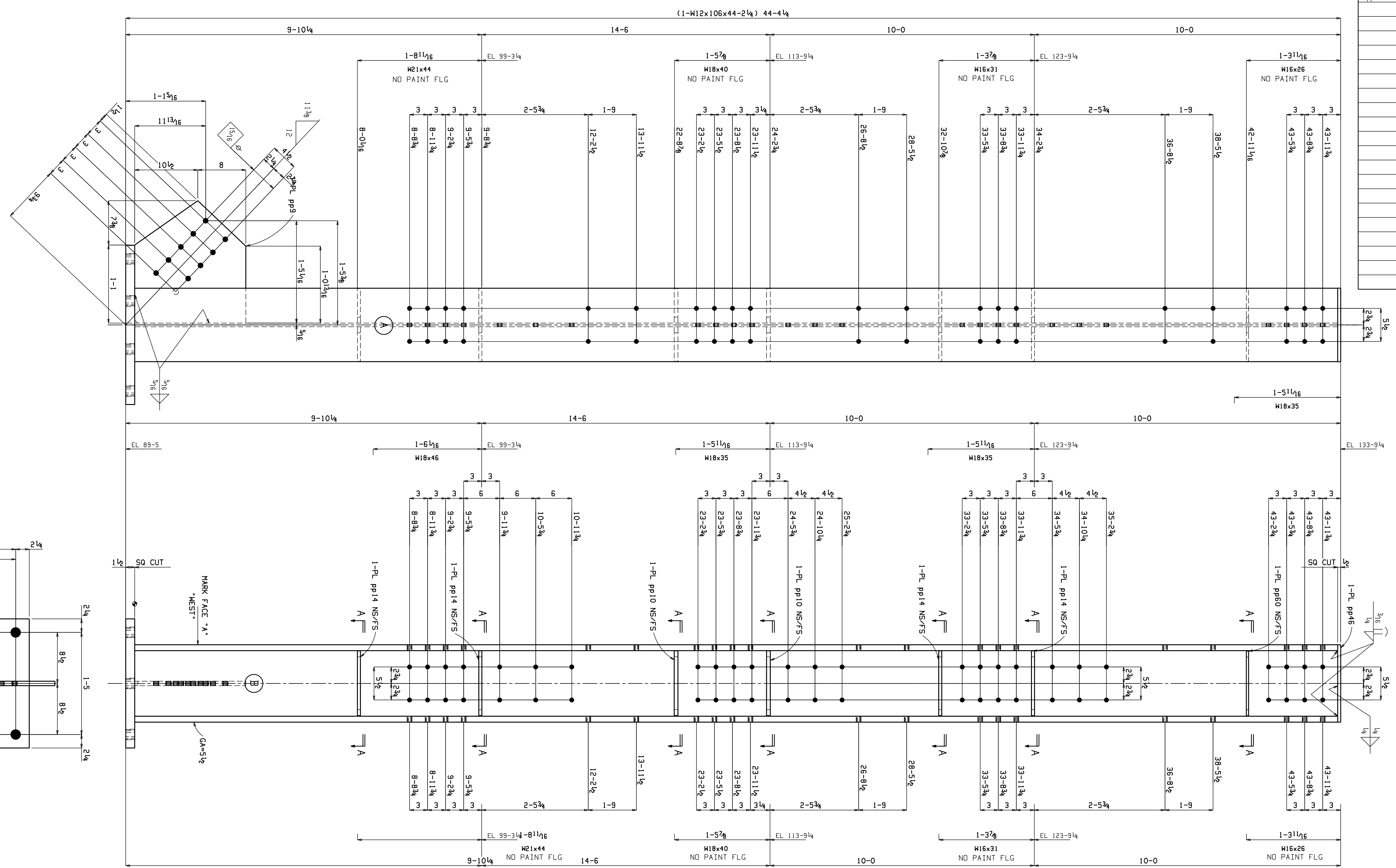

NOTE: FINAL FOR FAB & CONSTRUCTION

SHOP PLACE PIECE MARK ON LEFT HAND END OF MEMBER. ERECT MEMBER WITH PIECE MARK TO END SHOWN ON PLACEMENT PLAN	
DATE	DESCRIPTION
11-04-05	REV PER CHK & APPR

MATERIAL	ASTM A36 U.O.N.	HOLES	13 16
SURFACE PREP	SSPC-SP-3		
SHOP FINISH	STANDARD RED SHOP PRIMER 1.5 MIL.		
SUBJECT	SEQ. 01 COLUMN		
PROJECT			
LOCATION	JACKSONVILLE, ILLINOIS		
CUSTOMER			
DESIGNED BY			
DESIGN/ERECTION DWG REF	SS/E1		
DRAWN BY	DATE	CHECKED BY	DATE
WJS/TRJ	10-10-05	JFS	11-2-05
Job No.	1631	Sheet No.	32